

LASER PUMPED CESIUM MAGNETOMETER

LCS050G

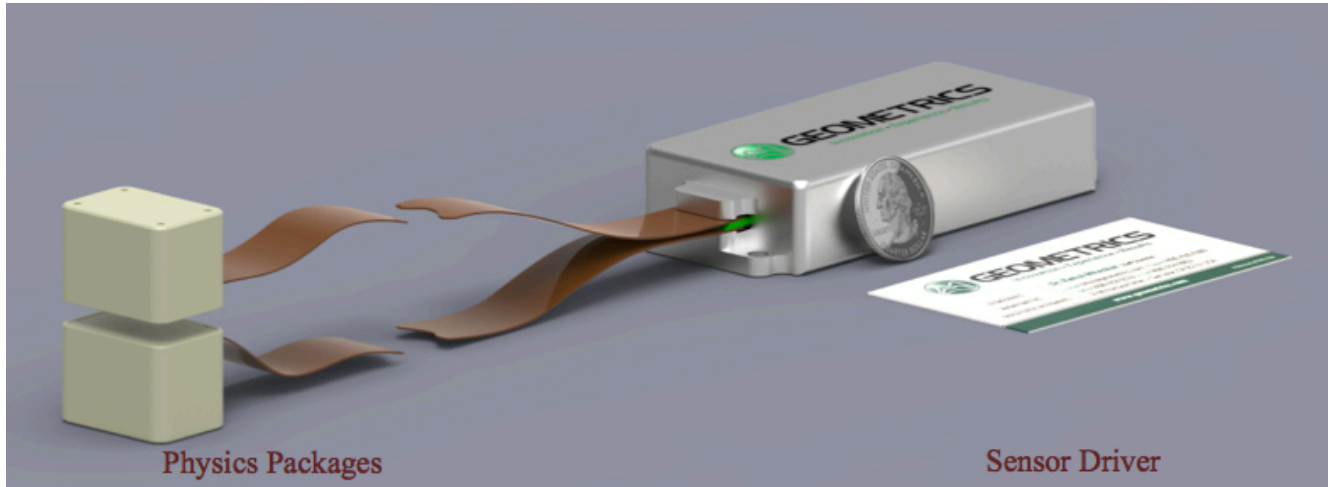

The Geometrics LCS050G is a laser pumped cesium magnetometer module that measures the total magnetic field strength, with a digital interface for easy integration with modular sensing platforms. The module features two sensors that can be used independently or as an intrinsic gradiometer. The sensors can also be arranged to compensate heading error or eliminate dead zone.



Features

Reconfigurable dual-sensor module for:

- Gradiometry
- Intrinsic heading error compensation
- Dead-zone free operation
- Small size:
 - 15 cm³ sensor
 - 200 cm³ electronics volume
- High performance:
 - 1 pT/ $\sqrt{\text{Hz}}$ noise typical
 - 1 kSps sample rate
- Low power operation:
 - 5 W power consumption
- Dead Zone:
 - Polar, $\pm 25^\circ$
- Modular architecture for versatile system integration

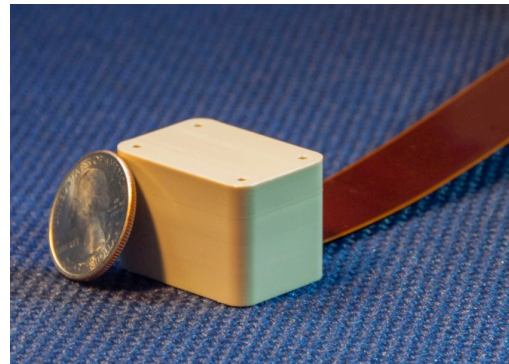

Applications:

- Autonomous Geophysical Surveys
- Non-destructive Evaluation
- Magnetocardiography
- Structural Health Monitoring

Specifications:

Characteristic	Condition	Min	Typ	Max	Units
----------------	-----------	-----	-----	-----	-------

Power Supply

Supply Voltage	Vin referenced to GND	9.5	12	16	Volts
Average Current Draw	Vin = 12V, 25 °C ambient temperature		0.4	0.6	A
	Vin = 12V, -35 °C ambient temperature		0.65	0.85	
Average Power Draw	25 °C ambient temperature		5	7	W
	-35 °C ambient temperature		8	10	

Performance

Field Range	Full scale	20		100	μT
Noise Floor	Magnetic field orthogonal to sensor optical axis		1	5	pT/√Hz
Dead Zone	Polar only, included angle		60	70	degree
Heading Error	Measured at 50μT field strength		25	40	nTp
Digital Resolution	32-bit magnetometer output		0.05		pT/LSb
Output Data Rate	Continuous measurement		1000		Hz

Environmental

Operating Temperature	Ambient	-35		50	°C
Storage Temperature	Ambient	-40		70	°C
Operating Altitude				10000	Feet
Storage Altitude				45000	Feet

Mechanical Specifications:

Dimensions in [mm] inches.

Sensor

Weight: 30g each, 2 sensors per magnetometer module.

Top View

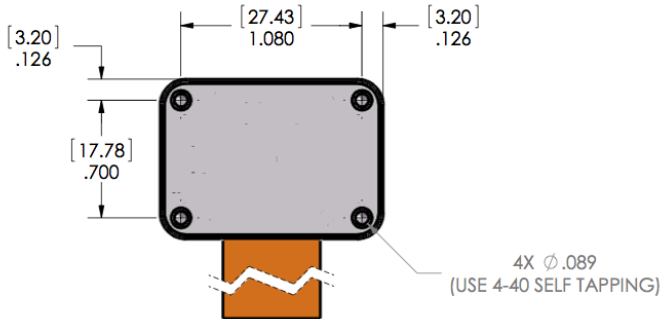

Bottom View

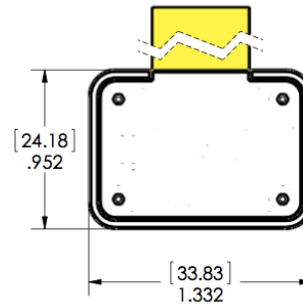

Front View

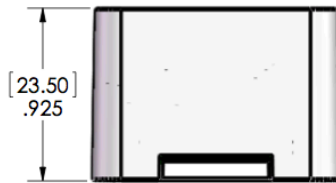

Side View

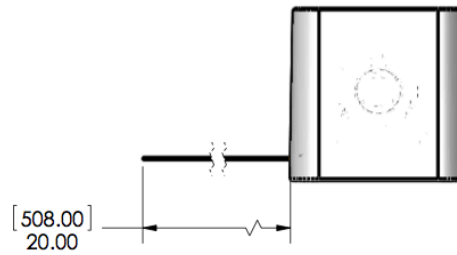

Driver Unit

Weight: 200g each.

Top View

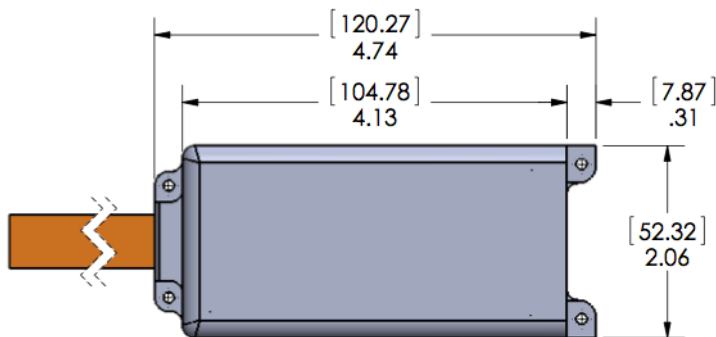

Connector Placement

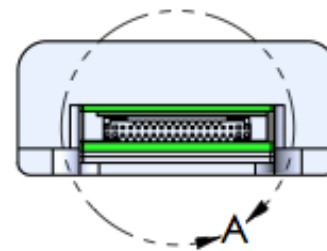

Side View

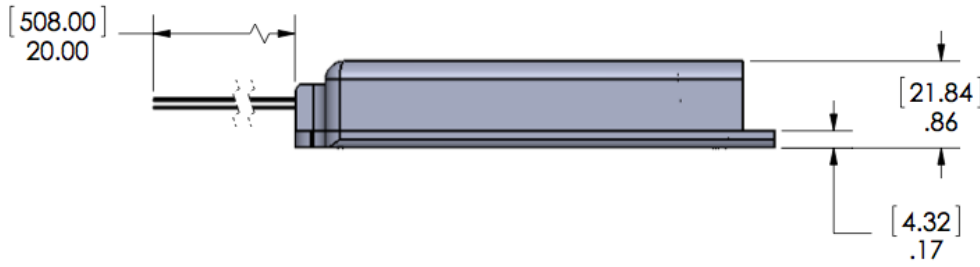

Bottom View

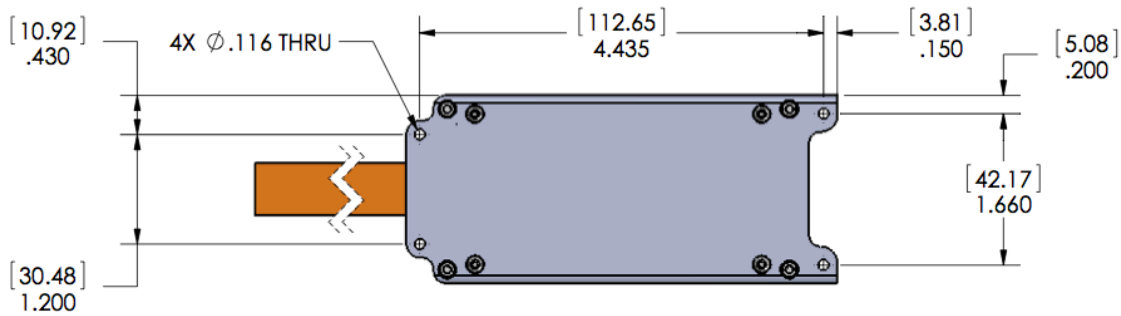

Connector Details

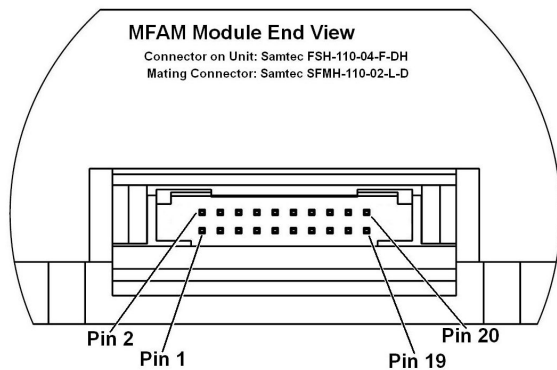

Connector on MFAM Module:

Samtec FSH-110-04-F-DH

Mating connector:

Samtec SFMH-110-02-L-D

Pin Configuration

Pin	Signal	Description
1	CHASSIS	Chassis ground
2	GND	Power supply ground
3	Vin	Power supply (9.5V to 16V)
4	Vin	Power supply (9.5V to 16V)
5	GND	Power supply ground
6	GND	Power supply ground
7	MSPI_DOUT	Data output (TX), SPI protocol, unit is master
8	DNC	Do not connect, leave pin open.
9	MSPI_DIN	Data input (RX), SPI protocol unit is master
10	DNC	Do not connect, leave pin open.
11	MSPI_SCLK	Clock output, SPI protocol, unit is master
12	DNC	Do not connect, leave pin open.
13	MSPI_CSB	Chip select, active low signal, SPI protocol, unit is master
14	DNC	Do not connect, leave pin open.
15	CTS	Clear To Send handshake signal, INPUT to MFAM unit (not implemented)
16	REF10M	10 MHz reference clock input, OPTIONAL
17	RTS	Ready To Send handshake signal, OUTPUT from MFAM unit (not implemented)
18	1PPS	1 pulse per second input, positive edge triggered
19	GND	Power supply ground
20	GND	Power supply ground

Document Information

Revision	Date	Description
0.1	8 July 2015	Document created.
0.2	1 Sep 2016	Updated specifications and formatting.
0.2a	21 Nov 2016	Updated to allow external sharing.
0.3	14 Mar 2017	Minor specification change.

Disclaimer

Information contained in this document is preliminary and incomplete. For further information, please contact:

Geometrics, Inc.
2190 Fortune Dr.
San Jose, CA 95131
USA.

Phone: +1-408-954-0522

Fax: +1-408-954-0902

E-mail: sales@geometrics.com

Web: www.geometrics.com