



# POCKET PENETROMETER

## OPERATING INSTRUCTIONS

### Instructions for use

1. Choose your test location with care to avoid gravel or other particles that would influence reading. Avoid obviously disturbed areas. For saturated cohesive soils, it is important that readings be taken in "fresh" samples or cut surfaces, since rapid drying will greatly influence the reading.
2. Return ring to back position against the penetrometer body, making sure the front edge is at the zero reading.
3. Grip the handle firmly, insert the shaft 6.35 mm (1/4") in depth with a smooth constant force into the soil mass or sample.
4. Take reading from the top of the indicator ring.

### Cleaning



Refer to the drawing below for item numbers.

1. Remove the retaining ring (6) from inner shaft (2).
2. Slide off indicator ring (4).
3. Unscrew end cap (3).
4. The spring (5) and inner shaft (2) can now be removed.
5. Wash all parts in warm soapy water and let air dry.
6. Reassemble in the reverse of the above procedure.



If, on reassembly, you find the spring has begun to collapse from use, you can shim the spring with standard 8 mm (5/16") washers. This is done by placing the washer on the pin extending from the end cap (3).



### Pocket penetrometer

1. Outer tube
2. Inner tube
3. End cap
4. Indicator ring
5. Spring
6. Retaining ring

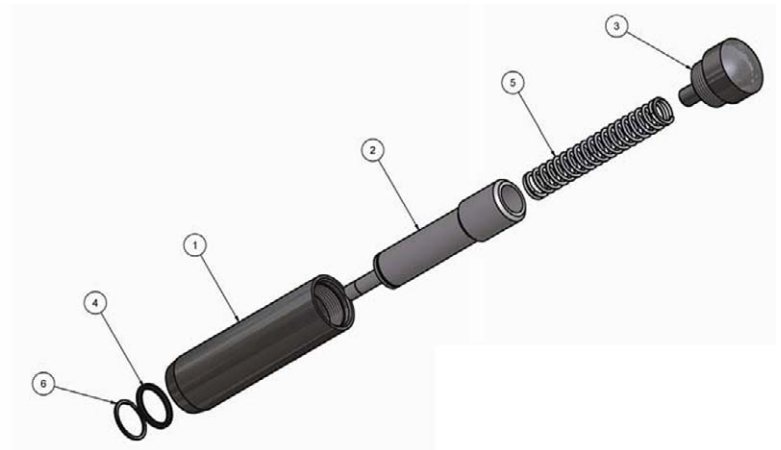

### Specifications

Accuracy of zero reading:  $\pm 0,25$  division  
 Spring constant:  $2.142 \pm 0.045$  kg/cm  
 ( $12 \pm 0.25$  lb/inch)

For calibration purposes:

Load required to read  $3 \text{ kg/cm}^2$  ( $=29,4 \text{ N/cm}^2=294 \text{ kPa}=3.0 \text{ ton/ft}^2$ ) =  $5.104 \pm 0.249$  kg ( $11.25 \pm 0.55$  lb)

Load required to read  $4.5 \text{ kg/cm}^2$  ( $=44,1 \text{ N/cm}^2=441 \text{ kPa}=4,5 \text{ ton/ft}^2$ ) =  $7.713 \pm 0.386$  kg ( $17 \pm 0.85$  lb)

Foot diameter: 6.35 mm (0.25 inch)

## All it takes for environmental research

P.O. Box 4, 6987 ZG Giesbeek,  
the Netherlands

T +31 313 88 02 00  
F +31 313 88 02 99

E info@eijkelkamp.com  
I www.eijkelkamp.com



a Royal Eijkelkamp Company

The pocket penetrometer has a spring constant of 2.142 kg/cm (12 pounds/inch). One kg/cm<sup>2</sup> (ton/ft<sup>2</sup>) interval on the scale is equivalent to 8 mm. Therefore, a compressive force of 1.71 kg (3.78 pounds) on the foot is required to read 1 kg/cm<sup>2</sup> (ton/ft<sup>2</sup>).

The equivalent of 1.71 kg (3.78 pounds) on a 0.316 cm<sup>2</sup> (.049 in<sup>2</sup>) (1/4" Diameter foot) is 5.41 kg/cm<sup>2</sup> = 530 kPa = 53 N/cm<sup>2</sup> or 5.53 tons/ft<sup>2</sup>.

Why does the Penetrometer need this very high force to read 1 kg/cm<sup>2</sup> (1 ton/ft<sup>2</sup>)? The penetrometer reading is taken by pushing its foot into the material to a depth of 6.35 mm (1/4"). For a depth of 6.35 mm (1/4"), the cylindrical surface area of the material to be sheared is 1.265 cm<sup>2</sup> (0.196 in<sup>2</sup>), just 4 times the area of the foot. This accounts for the large value of compressive force.

The pocket penetrometer is calibrated by correlation studies relating the effective spring compression to unconfined compressive strength values determined by other methods.

The pocket penetrometers are not individually calibrated; therefore, no calibration certificates are supplied with them. An error of up to 1/2 division on the scale equivalent to 0.125 kg/cm<sup>2</sup> (t/ft<sup>2</sup>) is possible with the instrument.

The data given above under "specifications" will be helpful for users of the instrument to check the accuracy of their units.

The pocket penetrometer can be compressed to any desired reading and the corresponding applied load can be determined using a platform scale or any compression machine having a readability better than 0.25 kg (0.5 lb).

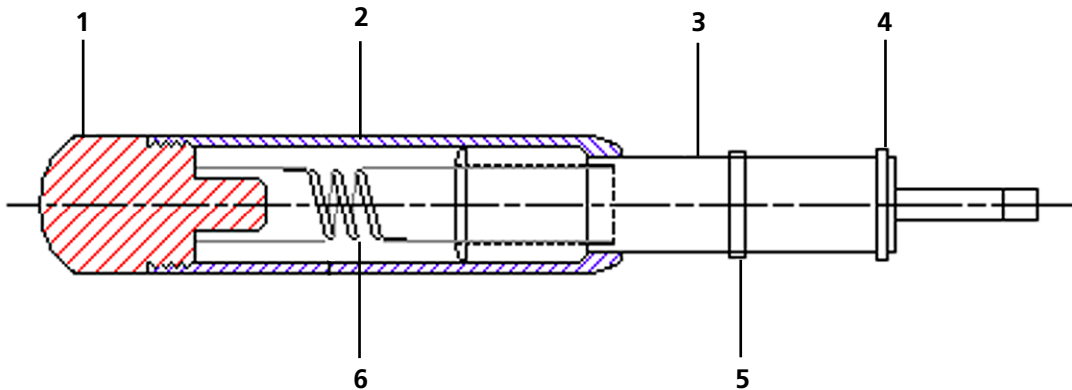

Nothing in this publication may be reproduced and/or made public by means of print, photocopy, microfilm or any other means without previous written permission from Eijkelkamp Agrisearch Equipment.

Technical data can be amended without prior notification.

Eijkelkamp Agrisearch Equipment is not responsible for (personal) damage due to (improper) use of the product.

Eijkelkamp Agrisearch Equipment is interested in your reactions and remarks about its products and operating instructions.